

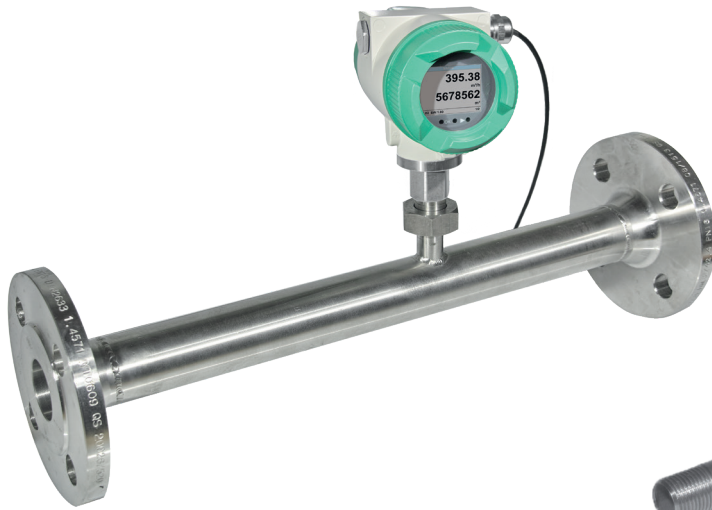

## VA 570 - Inline flow meter

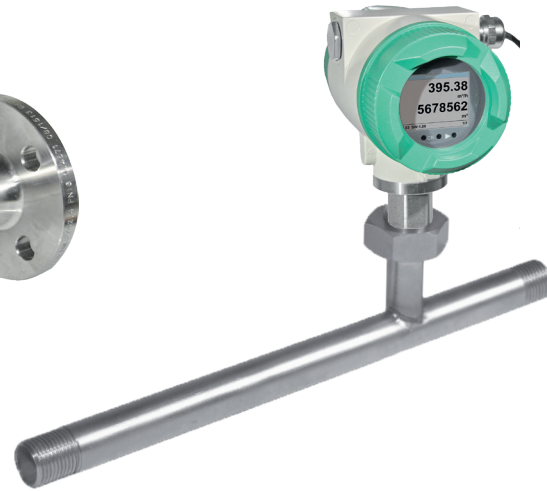

Flange version



Version for pipe with R thread or NPT thread

VA 570 is supplied with an integrated measuring section. The measuring sections are available in flanged version or with R resp. NPT thread.

A special feature is the removable measuring head. So the measuring unit can be removed easily and quickly for calibration or cleaning purposes without having to dismount the measuring section intricately. During this period the measuring section is sealed by a closing cap (accessory).

The screwing with a centring device is designed such that the sensor is positioned accurately in the center when screwing it into the measuring section; furthermore, it enables an exact positioning in the flow direction. This eliminates unnecessary measuring faults.

### Approvals:

II 2G Ex db IIC T4 Gb

II 2D Ex tb IIIC T90°C Db

### Special measurement technology features:

- 4 values on the display: Flow, total consumption, velocity, temperature. Units freely adjustable
- All measured values, settings such as gas type, inner diameter, serial number and so on can be accessed via Modbus-RTU
- Comprehensive diagnostic functions readable on the display or remote access via Modbus such as calibration cycle, error codes, serial number
- Notification in case of exceeding the calibration cycle
- Standard version accuracy 1.5% of m.v.  $\pm$  0.3% of f.s.
- Precision version accuracy 1.0% of m.v.  $\pm$  0.3% of f.s.
- Measuring span of 1 : 1000 (0.33 ft/s up to 735 ft/s)
- Configuration and diagnosis via display, hand-held device PI 500, PC service software on-site
- Gas type (air, nitrogen, oxygen, argon and so on) freely adjustable via PC service software or external device DS 400, DS 500, PI 500
- Reference conditions °C and PST / hPA freely adjustable
- In-Situ adjustment, leak flow volume suppression
- Pressure loss negligible



The sensor can be removed and cleaned

### Special mechanical features:

- Robust impact-proof aluminum die cast housing for the outdoor area IP 67
- All wetted parts made from stainless steel 1.4404
- On request with DVGW approval for natural gas (up to 232 psi)
- Pressure range up to 232 psi, special version up to 580 psi
- Media temperature range up to 356 °F (ATEX version up to 248 °F)
- No moveable parts, no wear
- Sensor tip very robust, easy to clean
- Housing rotatable, display rotatable by -356 °F



## Measuring range - Flow VA 570

		1/2"	3/4"	1"	1 1/4"	1 1/2"	2"	2 1/2"	3"
		m³/h (cfm)	m³/h (cfm)	m³/h (cfm)	m³/h (cfm)	m³/h (cfm)	m³/h (cfm)	m³/h (cfm)	m³/h (cfm)
<b>Reference conditions DIN 1945 / ISO 1217: 68 °F, 14 psi</b>									
<b>Air</b>	Low-Speed (164 ft/s)	20 (14)	45 (25)	75 (45)	140 (80)	195 (115)	320 (190)	550 (325)	765 (450)
	Standard (304 ft/s)	45 (25)	85 (50)	145 (85)	265 (155)	365 (215)	600 (350)	1025 (600)	1420 (835)
	Max (607 ft/s)	90 (50)	175 (100)	290 (170)	530 (310)	730 (430)	1195 (700)	2050 (1205)	2840 (1670)
	High-Speed (735 ft/s)	110(60)	215 (125)	355 (210)	640 (375)	885 (520)	1450 (850)	2480 (1460)	3440 (2025)
<b>Setting to DIN 1343: 32 °F, 14.7 psi</b>									
<b>Argon (Ar)</b>	Low-Speed (164 ft/s)	35 (20)	75 (40)	120 (70)	220 (130)	305 (180)	505 (295)	865 (510)	1200 (705)
	Standard (304 ft/s)	70 (40)	135 (80)	230 (135)	415 (245)	570 (335)	935 (550)	1605 (945)	2225 (1310)
	Max (607 ft/s)	140 (80)	275 (160)	460 (270)	830 (485)	1140 (670)	1870 (1100)	3205 (1885)	4440 (2615)
	High-Speed (735 ft/s)	170 (100)	335 (195)	555 (325)	1005 (590)	1385 (815)	2265 (1330)	3880 (2285)	5380 (3165)
<b>Carbondioxide (CO2)</b>	Low-Speed (164 ft/s)	20 (14)	45 (25)	75 (45)	140 (80)	195 (115)	320 (185)	545 (320)	760 (445)
	Standard (304 ft/s)	45 (25)	85 (50)	145 (85)	260 (155)	360 (210)	590 (345)	1015 (595)	1405 (825)
	Max (607 ft/s)	90 (50)	175 (100)	290 (170)	525 (305)	720 (425)	1185 (695)	2030 (1190)	2810 (1655)
	High-Speed (735 ft/s)	105 (60)	210 (125)	350 (205)	635 (370)	875 (515)	1430 (840)	2455 (1445)	3405 (2000)
<b>Nitrogen (N2)</b>	Low-Speed (164 ft/s)	20 (13)	40 (25)	70 (40)	130 (75)	180 (105)	295 (175)	505 (300)	705 (415)
	Standard (304 ft/s)	40 (20)	80 (45)	135 (75)	240 (140)	335 (195)	550 (320)	945 (555)	1305 (770)
	Max (607 ft/s)	80 (45)	160 (95)	270 (155)	485 (285)	670 (395)	1100 (645)	1885 (1110)	2610 (1535)
	High-Speed (735 ft/s)	100 (55)	195 (115)	325 (190)	590 (345)	815 (475)	1330 (780)	2280 (1340)	3165 (1860)
<b>Oxygen (O2)</b>	Low-Speed (164 ft/s)	20 (13)	45 (25)	75 (40)	135 (80)	185 (110)	305 (180)	525 (310)	730 (430)
	Standard (304 ft/s)	40 (25)	80 (45)	140 (80)	250 (145)	345 (205)	570 (335)	980 (575)	1355 (795)
	Max (607 ft/s)	85 (50)	165 (95)	280 (165)	505 (295)	695 (410)	1140 (670)	1955 (1150)	2710 (1590)
	High-Speed (735 ft/s)	105 (60)	205 (120)	340 (200)	610 (360)	845 (495)	1380 (810)	2365 (1390)	3280 (1930)
<b>Nitrous oxide (N2O)</b>	Low-Speed (164 ft/s)	20 (14)	45 (25)	75 (45)	140 (80)	190 (110)	315 (185)	540 (320)	750 (440)
	Standard (304 ft/s)	40 (25)	85 (50)	140 (85)	260 (150)	355 (210)	585 (345)	1005 (590)	1395 (820)
	Max (607 ft/s)	85 (50)	170 (100)	285 (170)	520 (305)	715 (420)	1170 (690)	2010 (1180)	2785 (1640)
	High-Speed (735 ft/s)	105 (60)	210 (120)	345 (205)	630 (370)	865 (510)	1420 (835)	2435 (1430)	3375 (1985)
<b>Natural gas (NG)</b>	Low-Speed (164 ft/s)	14,4 (8)	25 (15)	45 (25)	85 (50)	115 (65)	190 (110)	325 (190)	450 (265)
	Standard (304 ft/s)	25 (15)	50 (30)	85 (50)	155 (90)	215 (125)	355 (205)	605 (355)	840 (495)
	Max (607 ft/s)	50 (30)	105 (60)	170 (100)	310 (185)	430 (250)	705 (415)	1210 (710)	1680 (985)
	High-Speed (735 ft/s)	65 (35)	125 (70)	210 (120)	380 (220)	520 (305)	855 (500)	1465 (865)	2035 (1195)



### Optional: Connection to different Bus systems

There are different options available for connection to modern Bus systems:

- Ethernet interface (Modbus-TCP) / PoE
- M-BUS
- Modbus-RTU
- Profibus DP interface (in process)
- Profinet interface (in process)
- HART (in process)



Ethernet Modbus TCP

M12 Ethernet port, x-coded

For further accessories refer to pages 116 to 120

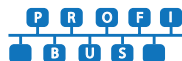



## VA 570 - Inline flow meter

Example order code VA 570:

0695 0570\_A1\_B1\_C1\_D1\_E1\_F1\_G1\_H1\_I1\_J1\_K1\_L1\_M1\_R1

Process connection	
A1	R male thread
A2	NPT male thread
A3	Flange DIN EN 1092-1
A4	Flange ANSI 16.5 Class 150 lbs
A5	Flange ANSI 16.5 Class 300 lbs

Display option	
B1	with integrated display
B2	without display

Option signal outputs / bus connection	
C1	2 units 4...20 mA analog output (electrically isolated), pulse output, RS 485 (Modbus-RTU)
C4	1 x 4...20 mA analog output (not electrically isolated), pulse output, RS 485 (Modbus-RTU)
C5	Ethernet interface (Modbus / TCP), 1 x 4...20 mA analog output (not electrically isolated), pulse output, RS 485 (Modbus-RTU)
C8	M-Bus, 1 x 4...20 mA analog output (not electrically isolated), pulse output, RS 485 (Modbus-RTU)
C9	Ethernet interface PoE (Power over Ethernet) (Modbus / TCP), 1 x 4...20 mA analog output (not electrically isolated), pulse output, RS 485 (Modbus-RTU)

Adjustment/calibration	
D1	No real gas adjustment - gas type configuration per gas constant
D2	Real gas adjustment in the gas type selected below

Gas type	
E1	Compressed air
E2	Nitrogen (N2)
E3	Argon (Ar)
E4	Carbon dioxide (CO2)
E5	Oxygen (O2)
E6	Nitrous oxide (N2O)
E7	Natural gas (NG)
E8	Helium (He) (real gas adjustment <b>D2</b> required)
E9	Propane (C3H8) (real gas adjustment <b>D2</b> required)
E10	Methane (CH4)
E11	Biogas (methane 50% : CO2 50%)
E12	Hydrogen (H2) (real gas adjustment <b>D2</b> required)
E90	Further gas / please indicate gas type (on request)
E91	Gas mixture / please indicate mixture ratio (on request)

Reference standard	
F1	68 °F, 14.5 psi
F2	32 °F, 14.7 psi
F3	59 °F, 14.22 psi
F4	59 °F, 14.7 psi

Maximum pressure	
G1	232 psi
G2	580 psi

Surface condition	
H1	standard version
H2	Special cleaning - oil and grease free (e. g. for oxygen applications and so on)
H3	Silicone-free version including special cleaning oil- and grease-free

Accuracy class	
I1	± 1.5% of the measured value ± 0.3% f.s. (standard)
I2	± 1% of the measured value ± 0.3% f.s. (precision)

Maximum gas temperature on the sensor tip	
J1	up to 248 °F gas temperature (only for ATEX version)
J2	up to 356 °F gas temperature (standard)

Approvals	
K1	Non-explosive area - no approval
K2	ATEX II 2G Ex d IIC T4 Gb ATEX II 2D Ex tb IIC T90°C Db
K3	DVGW approval for natural gas (max. pressure 232 psi)

Measuring range (see table)	
M1	Max version (607 ft/s)
M2	Low-speed version (164 ft/s)
M3	Standard version (304 ft/s)
M4	High-speed version (735 ft/s)

Special measuring range	
R1	Special measuring range (please specify when placing order)



## Order no. VA 570

DESCRIPTION	ORDER NO.	TECHNICAL DATA VA 570
VA 570 flow meter with integrated 1/2" measuring section	0695 0570 + order code A...R_	<b>Measuring range VA 570:</b> up to 164 SCFM, low-speed version* up to 304 SCFM, standard version* up to 607 SCFM, max. version* up to 735 SCFM, high-speed version* * Measuring range Nm <sup>3</sup> /h for different pipe diameters and gases, see table measuring ranges flow * All measured values related to DIN 1343 standard conditions 32 °F and 14.7 psi ex works  <b>Accuracy:</b> <b>Accuracy class</b> <b>(o. M. V. = of measured value)</b> <b>(o. F. S. = of full scale)</b> <b>Accuracy indications:</b> relative to ambient temperature 71.6 °F ± 2 °F, system pressure 6 bar  <b>Repeatability:</b> 0.25% of m.v. in case of correct mounting (mounting aid, position, inlet section)  <b>Measuring principle:</b> Thermal mass flow sensor <b>Response time:</b> t90 < 3 s <b>Operating / ambient temperature range:</b> -4...158 °F <b>Media temperature range:</b> -4 °F .... 356 °F (ATEX version: -4 °F ... 248 °C) <b>Adjustment possibilities via display, external handheld device PI 500, PC Service Software, remote diagnosis:</b> Nm <sup>3</sup> /h, Nm <sup>3</sup> /min, NI/min, l/s, ft/min, cfm, kg/h, kg/min, inner diameter, reference conditions ° C/° F, mbar/hPa, zero point correction, leak flow volume suppression, scaling analog output 4...20 mA, pulse/alarm, error codes etc.  <b>Outputs:</b> Standard: 1 x 4...20 mA analog output (not electrically isolated), pulse output, RS 485 (Modbus-RTU) <b>Optional:</b> 2 x 4 ... 20 mA active, Modbus TCP, HART, Profibus DP, Profinet, M-Bus  <b>Burden:</b> < 500 Ohm <b>Additional average value calculation:</b> for all parameters freely adjustable from 1 minute up to 1 day, e. g. 1/2 hours average value, average day value  <b>Protection class:</b> IP 67 IP 64 for ATEX II 2D Ex tb IIIC T90°C Db <b>Material:</b> Die-cast aluminum housing, sensor tube stainless steel 1.4404 <b>Operating pressure:</b> 232 psi, in special version 580 psi <b>Power supply:</b> 18...36 VDC, 5 W <b>Approval:</b> ATEX II 2G Ex db IIIC T4 Gb ATEX II 2D Ex tb IIIC T90°C Db DVGW
VA 570 flow meter with integrated 3/4" measuring section	0695 0571	
VA 570 flow meter with integrated 1" measuring section	0695 0572	
VA 570 flow meter with integrated 1 1/4" measuring section	0695 0573	
VA 570 flow meter with integrated 1 1/2" measuring section	0695 0574	
VA 570 flow meter with integrated 2" measuring section	0695 0575	
VA 570 flow meter with integrated 1/2" measuring section with flange	0695 2570	
VA 570 flow meter with integrated 3/4" measuring section with flange	0695 2571	
VA 570 flow meter with integrated 1" measuring section with flange	0695 2572	
VA 570 flow meter with integrated 1 1/4" measuring section with flange	0695 2573	
VA 570 flow meter with integrated 1 1/2" measuring section with flange	0695 2574	
VA 570 flow meter with integrated 2" measuring section with flange	0695 2575	
VA 570 flow meter with integrated 2 1/2" measuring section with flange	0695 2576	
VA 570 flow meter with integrated 3" measuring section with flange	0695 2577	
<b>Further accessories:</b>		
Closing cap for measuring section in aluminum	0190 0001	
Closing cap for measuring section stainless steel 1.4404	0190 0002	
Connection cable for probes 16 ft with open ends	0553 0108	
Connection cable for probes 32.81 ft with open ends	0553 0109	
Ethernet connection cable length 16 ft, M12 plug x-coded (8 pin) to RJ 45 plug	0553 2503	
Ethernet connection cable length 32.81 ft, M12 plug x-coded (8 pin) to RJ 45 plug	0553 2504	
Mains unit in wall housing for maximum 2 sensors of the series VA/FA 5xx, 100-240 V, 23 VA, 50-60 Hz / 24 VDC, 0.35 A	0554 0110	
ISO calibration certificate at 5 measuring points for VA sensors	3200 0001	
Additional calibration point (point freely selectable) Volume flow	0700 7720	
CS Service Software VA 550 incl. interface cable to PC (USB) and power supply - for configuration / parametrisation of VA 550	0554 2007	
PNG cable screwing - standard VA 550/570	0553 0552	
PNG cable screwing - for ATEX version VA 550/570	0553 0551	

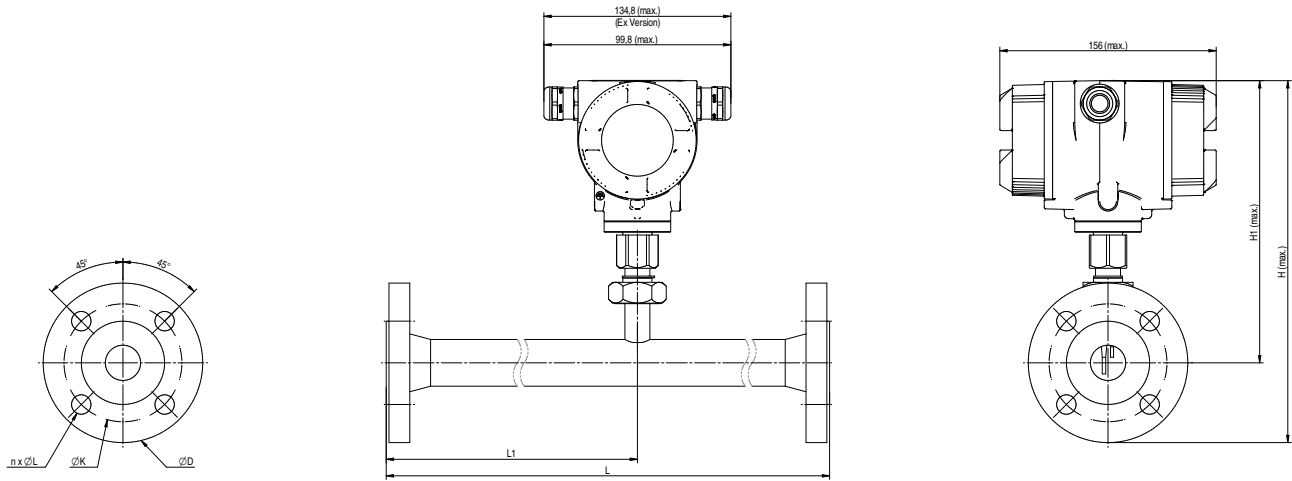

### VA 570 - with flange

							Flange DIN EN 1092-1		
Pipe size	AD pipe - mm	ID pipe - mm	L - Inch	L1 - Inch	H - Inch	H1 - Inch	Ø D mm	Ø K mm	n x Ø L mm
1/2"	21.3	16.1	11.80*	8.27	10.51	8.58	95	65	4 x 14
3/4"	26.9	21.7	18.70*	10.83	10.63	8.58	105	75	4 x 14
1"	33.7	27.3	18.70*	10.83	10.83	8.58	115	85	4 x 14
1 1/4"	42.4	36.0	18.70*	10.83	11.34	8.58	140	100	4 x 18
1 1/2"	48.3	41.9	18.70*	10.83	11.55	8.58	150	110	4 x 18
2"	60.3	53.1	18.70*	10.83	11.81	8.58	165	125	4 x 18
2 1/2"	76.1	68.9	18.70*	10.83	12.60	8.98	185	145	8 x 18
3"	88.9	80.9	18.70*	10.83	12.91	8.98	200	160	8 x 18

\*Attention: Shortened inlet section. Please observe the recommended minimum inlet section (length = 15 x inner diameter)!

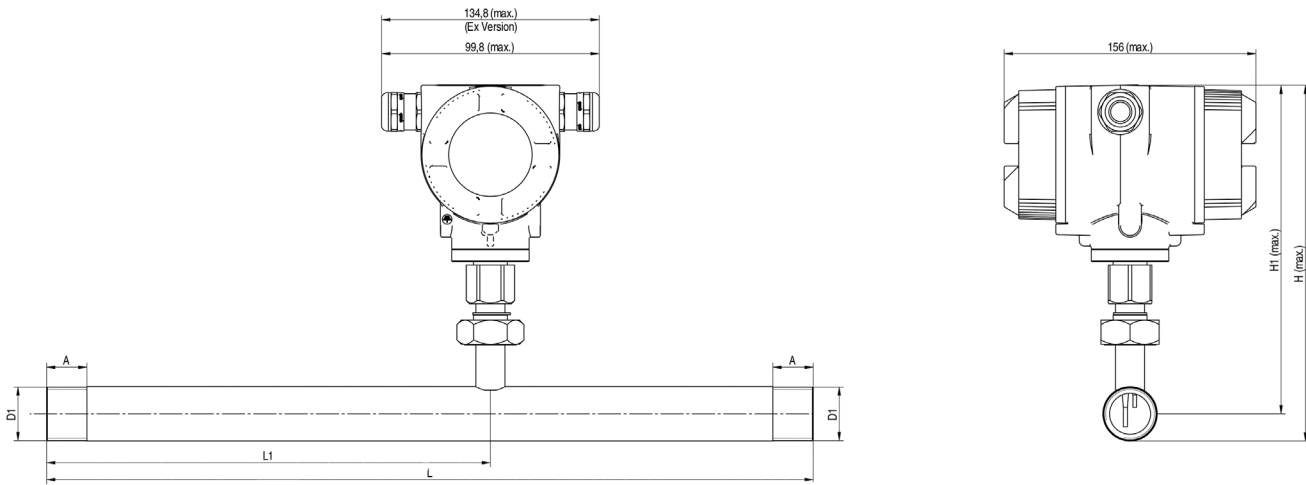

### VA 570 - Threaded version

Connection thread	AD pipe - mm	ID pipe - mm	L - Inch	L1 - Inch	H - Inch	H1 - Inch	A - Inch
R 1/2"	21.3	16.1	11.80*	8.27	8.98	8.58	0.79
R 3/4"	26.9	21.7	18.70*	10.83	9.09	8.58	0.79
R 1"	33.7	27.3	18.70*	10.83	9.25	8.58	0.98
R 1 1/4"	42.4	36.0	18.70*	10.83	9.41	8.58	0.98
R 1 1/2"	48.3	41.9	18.70*	10.83	9.53	8.58	0.98
R 2"	60.3	53.1	18.70*	10.83	9.76	8.58	1.18

\*Attention: Shortened inlet section. Please observe the recommended minimum inlet section (length = 15 x inner diameter) on site!